

INGESOLAR 150DAUL THERMOSYPHON EQUIPMENT

UP TO 1 - 4 PEOPLE



Composed by:

- 1 Solar collector INGESOL-AR
- Double coil hot water tank ACS IGSC 150 UL
- Production capacity of **200 liters** of hot water
- Hidraulic elements kit
- Structure for flat or slopin roof. Possibility of different angles depending on the architectural integration

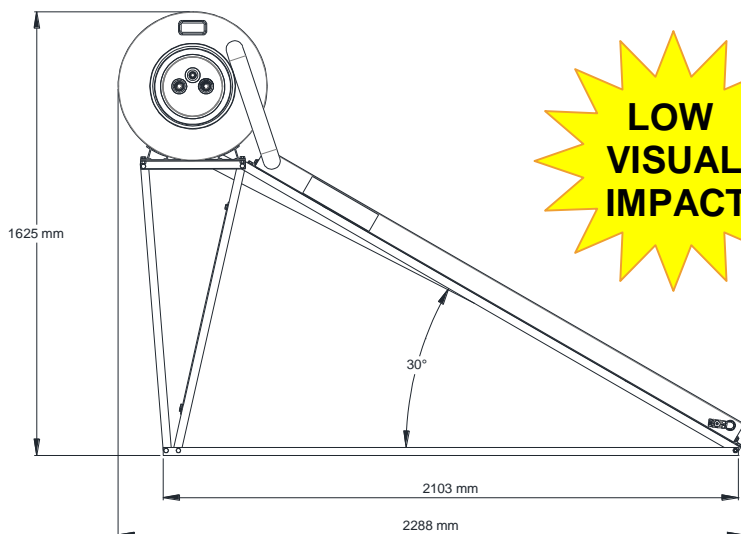

**LOW
VISUAL
IMPACT**

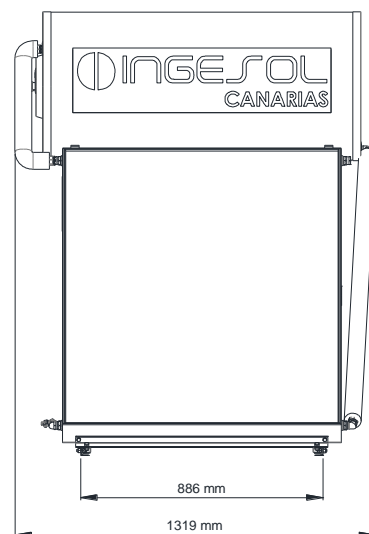

AUTHORIZED INSTALLER:

INGESOLAR 150DAUL

SOLAS COLLECT INGESOL-AR **NPS 29314**

- High performance selective absorber (BLUETEC)
- Ultralight Solar Collector weighing 30 kg
- Tempered solar glass and printed on the inside
- No screws or rivets
- Back of lacquered aluminum and sides of marine anodized aluminum
- Isolation of the bottom and sides with Compact CFC free polyurethane
- Box made of only one piece
- Total surface 2,06 m²
- Opening surface 1,95 m²
- Dimensions (mm):
2.020 x 1.020 x 80
- Maximum quality



**Production process quality certified
according to ISO 9001**

